

# marathon™

CMG Motors

HLA series  
Cast aluminium multi-mount

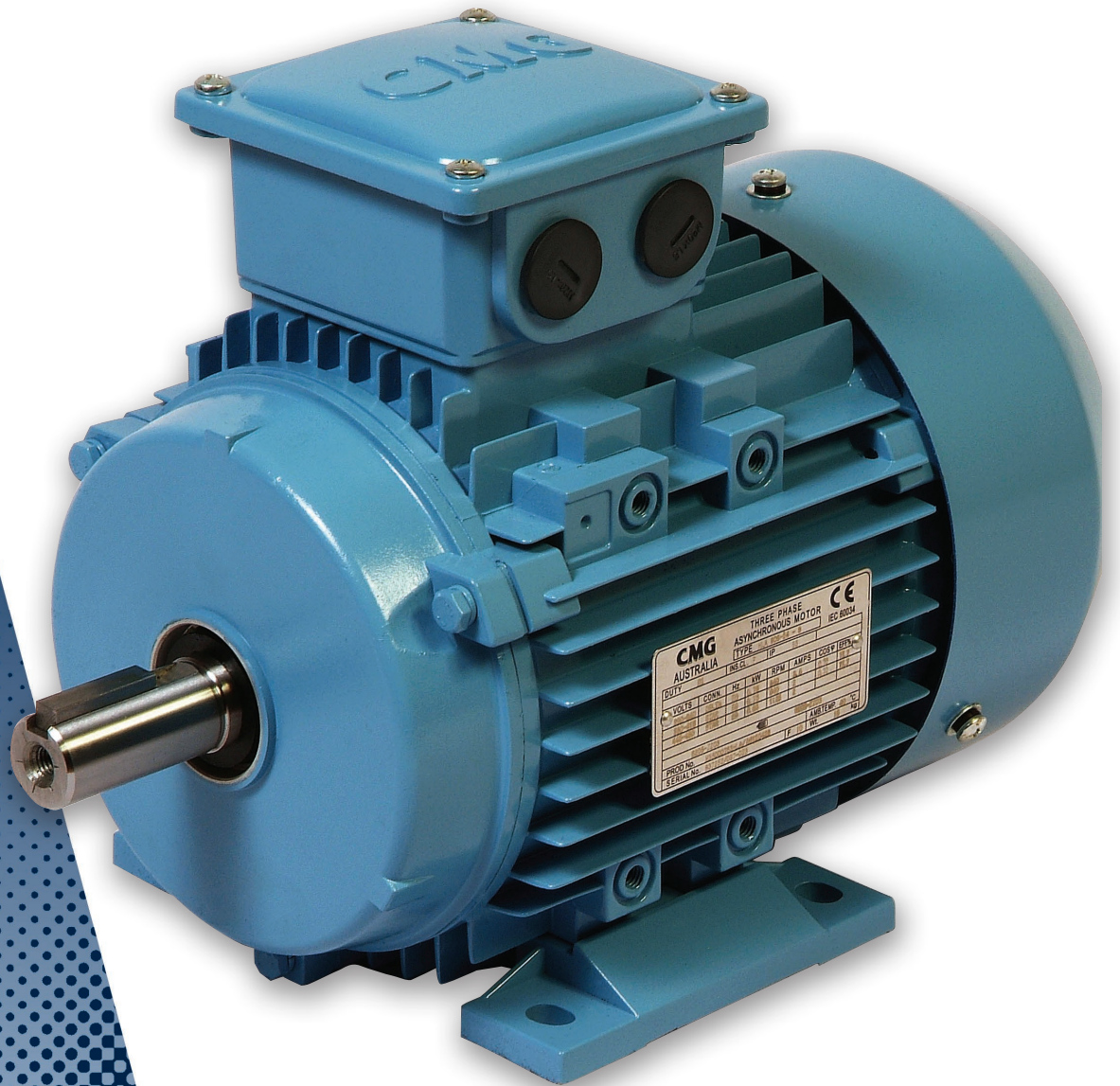

A Regal Brand

**REGAL**

**REGAL**

**marathon**<sup>™</sup>  
CMG Motors

“We convert power into motion to help the world run more efficiently”

BUSINESS PURPOSE

## ABOUT US

Regal Beloit Corporation is a leading manufacturer of electric motors, mechanical and electrical motion controls and power generation products serving markets throughout the world. Regal Beloit is headquartered in Beloit, Wisconsin, and has manufacturing, sales and service facilities throughout the United States, Canada, Mexico, Europe and Asia.

Regal Australia brings together the strength and experience of three of Australia’s leading suppliers of engineered industrial products. CMG, OBA and Transmission Australia are now in a position to offer industry an unparalleled range of products under the Regal Australia banner.

Our products are efficient and innovative; they conform to Australian design, performance and engineering standards. Regal Australia sources products from Regal manufacturing facilities and represents some of the world’s leading industrial manufactures.

Regal Australia embraces the company core values of Integrity, High Energy and Performance and has adopted the initiatives of customer care, globalization, innovation, sustainability and simplification.

Our company business statement is that “We convert power into motion to help the world run more efficiently” has direct lineage to our core values and initiatives.

**REGAL**

OUR CORE VALUES



### Integrity

We are a company that is honest, trustworthy, candid, transparent and fair.

### High Energy

Our culture promotes a strong work ethic with high energy teams fostering a culture of inclusion and respect for all.

### Performance

Everyone is expected to perform and our stakeholders count on us to execute, meet commitments and continuously improve.

**REGAL**

OUR INITIATIVES



### Customer Care

Our future depends on the success of our customers. We will establish closer relationships with our customers, actively listen to their feedback and respond with a sense of urgency.



### Globalization

We want to be global for three reasons. First, we want to participate in high growth markets around the world. Second, many of our customers are global and we want to serve customers where they do business. Finally, we want to utilize our global capabilities to seek out the best talent and to remain globally competitive.



### Innovation

We will build the future of the Company on products that are new and needed. While we accept that with an innovation headset comes a certain degree of risk, we are committed to investing in new products, technologies and processes that deliver real value to our customers.



### Sustainability

The long term sustainability of our Company requires not only continuous growth and profitability, but also that we take personal responsibility for the impact we have on our planet, and for the fair and just treatment of the people we employ.



### Simplification

Complexity is a serious disadvantage in business. We aim to simplify every aspect of our operations to eliminate complexities in order to increase our speed, improve our flexibility and reduce our costs.

# HLA cast aluminium multi-mount three phase motors Sizes 80 to 132, 0.75 to 7.5kW

## Motor design

Regal Australia's HLA series motors are an ideal example of Regal Australia's enhanced performance motors.

Building on the proven performance of the popular SLA series, Regal Australia has developed the HLA series to meet the demands of more efficient electric motors. Incorporating all of the mechanical features of the SLA series the HLA series complies with the new Australian standard for minimum efficiency (MEPS2).

## Standards and specifications

The main dimensions and rated outputs of the HLA series generally conform to Australian Standard AS1359 and International Standards IEC 60034 and IEC 60072.

## Multi-mount feature

The standard HLA motor is supplied with the terminal box top mounted, and has detachable feet. The unique multi-mount design allows the motor feet to be removed and the motor mounted from any of the 16 mounting pads. This feature means that for axial flow fans, there is no need for a motor mount in the fan case, which enables quicker assembly times, lower cost, and less restriction to air flow.

Alternatively the feet may be relocated to either side, for a wall mounted motor or side mounted terminal box.

## Operating parameters

Standard HLA series motors are designed with the following parameters:

- Continuous duty (S1)
- Three phase 380-415V, 50Hz power supply
- Ambient temperatures up to 40°C
- Installation at altitudes up to 1000 metres

Performance data is based on these parameters and may need adjustment for different requirements.

## F class insulation, B class temperature rise

HLA series motors have F class insulation and B class temperature rise which gives them good service factor capabilities.

## Degree of protection

Standard level of enclosure protection for the HLA series is IP55, with increased ratings available on request.

## Pump application

A locked drive end bearing is standard on all HLA flange mounted motors from 90 to 160 frame. This makes it perfect for pump applications where minimal axial shaft movement is critical to provide tight tolerances for impellers. On request Regal Australia can provide a locked bearing option for smaller frame sizes and foot mounted motors.

## Air movement application

Low weight design and the standard drilled and tapped hole in the shaft makes the HLA series ideally suited for all air movement applications.

## Paint finish

Motors are painted with a high quality enamel finish. The standard colour is pastel blue (RAL5024), with other colours available on request.

## MEPS compliance (Eff 1)

HLA motor efficiency levels comply to the Minimum Efficiency Requirements as per AS/NZS 1359.5:2006 (equivalent to European standard Eff 1).

## Bearings

Bearings fitted are a deep groove ball type with double seals and are the same size for both ends.

Motor frame	Bearing Size
80	6204-2RS
90S/L	6205-2RS
100L	6206-2RS
112M	6206-2RS
132S/M	6208-2RS
160M/L	6309-2RS

## Terminal box

The terminal box of the HLA series is separate from the body of the motor allowing it to be rotated providing ease of connection to supply.

## Internal connections, voltages and VF drive selection

Standard terminal connections for motors 3kW and below is 230V Delta / 400V Star. These motors are suitable for operation with 230V three phase Variable Frequency Drives or 400V DOL starting.

Standard terminal connections for motors 4kW and above is 400V Delta / 690V Star. These motors are suitable for operation with 400V three phase Variable Frequency Drives, 400V Star/Delta or 400V DOL starting.

## Product code specification

When placing an order the motor product code should be specified. The product code of the motor is composed in accordance with the following example:

M	3	2	0	0	1	5	0	3	H	L	A	
1	2	3	4-8					9	10-12		13	

### Position 1

**M** = metric frame size

### Position 2

#### Phase

**3** = Three phase

**A** = 2 speed fan duty single winding

**B** = 2 speed fan duty separate windings

### Position 3

#### Number of poles

**2** = 2 poles

**4** = 4 poles

**6** = 6 poles

**8** = 8 poles

**E** = 2/4 poles

**J** = 4/6 poles

**K** = 4/8 poles

**N** = 6/8 poles

**P** = 6/12 poles

**S** = 8/16 poles

### Positions 4 to 8

Rated power output  
(kW x 100)

(refers to kW at high speed for 2 speed motors)

### Position 9

#### Mounting arrangements

**3** = B3

**4** = B3/B5      **5** = B5

**6** = B3/B14A    **7** = B14A

**8** = B3/B14B    **9** = B14B

**0** = Body mount

### Positions 10 to 12

#### Series

**HLA** = HLA series

### Position 13

#### Variation suffix

**Blank** = standard

**F** = flying leads

**H** = H class insulation

**P** = pad mount (fitted pads)

**R** = airstream rated

# Performance data

HLA series, three phase, 380-415V 50Hz

IP55, F class insulation , B class temperature rise

kW	Motor frame	Speed [ r/min ]	400V 50Hz						380V 50Hz			415V 50Hz		Weight of foot mount motor [ kg ]	
			Efficiency		Power factor		Current		Torque			Current	Current		
			at % full load		at % full load		Full load $I_N$ [ A ]	Locked rotor $I_L/I_N$	Full load $T_N$ [ Nm ]	Locked rotor $T_L/T_N$	Break down $T_B/T_N$	Full load $I_N$ [ A ]	Full load $I_N$ [ A ]		Moment of inertia $J=1/4GD^2$ [ kg·m <sup>2</sup> ]
			100 [ % ]	75 [ % ]	100 [ % ]	75 [ % ]									
<b>3000 r/min = 2 poles</b>															
0.75	80A - 19	2850	83.4	84.2	0.86	0.81	1.50	7.0	2.5	3.1	3.4	1.57	1.47	0.00085	12
1.1	80B - 19	2835	84.4	85.9	0.87	0.83	2.2	7.3	3.7	3.0	3.3	2.3	2.1	0.00099	13
1.5	90S - 24	2860	86.4	87.0	0.86	0.81	2.9	8.4	5.0	3.9	4.0	3.0	2.9	0.0014	15
2.2	90L - 24	2860	86.5	87.3	0.85	0.80	4.3	8.7	7.4	4.1	4.2	4.4	4.2	0.0016	16
3	100L - 28	2890	86.7	87.0	0.87	0.82	5.7	9.0	9.9	3.0	3.4	6.0	5.5	0.0035	27
4	112M - 28	2915	89.6	90.1	0.90	0.86	7.1	9.2	13.1	3.0	3.6	7.4	7.0	0.0062	33
5.5	132SA - 38	2925	90.2	90.5	0.89	0.85	9.9	8.0	18.0	2.3	3.2	10.3	9.7	0.013	45
7.5	132SB - 38	2920	90.6	91.1	0.89	0.87	13.3	7.9	24.5	2.3	2.9	13.9	13.0	0.015	50
11	160MA - 42	2950	92.0	91.9	0.88	0.83	19.5	8.0	35.6	2.3	3.2	20.3	19.1	0.045	73
15	160MB - 42	2945	92.4	92.2	0.88	0.86	26.4	7.8	48.6	2.1	2.9	27.4	25.9	0.051	82
18.5	160L - 42	2935	92.2	92.3	0.89	0.86	32.5	7.6	60.2	2.1	2.7	34.0	31.7	0.057	84
<b>1500 r/min = 4 poles</b>															
0.75	80B - 19	1410	82.2	82.5	0.72	0.63	1.85	7.5	5.1	2.3	2.6	1.90	1.80	0.0023	14
1.1	90S - 24	1425	84.0	84.6	0.74	0.66	2.6	6.2	7.4	2.9	3.0	2.6	2.5	0.0026	17
1.5	90L - 24	1430	86.2	86.9	0.75	0.68	3.4	7.0	10.0	3.1	3.4	3.4	3.3	0.0029	18
2.2	100LA - 28	1455	86.5	86.1	0.78	0.71	4.7	8.3	14.4	3.1	3.5	4.8	4.7	0.0058	24
3	100LB - 28	1455	87.4	87.4	0.79	0.74	6.2	8.0	19.7	2.7	3.0	6.5	6.0	0.0071	29
4	112M - 28	1455	88.9	89.2	0.79	0.74	8.2	7.3	26.3	2.6	3.1	8.4	8.1	0.011	31
5.5	132S - 38	1460	90.2	90.6	0.83	0.80	10.6	7.1	36.0	2.0	2.7	11.0	10.4	0.023	53
7.5	132M - 38	1455	90.5	91.0	0.84	0.80	14.3	7.4	49.2	2.3	2.8	14.9	14.0	0.032	63
11	160M - 42	1470	91.0	90.9	0.84	0.79	20.7	7.4	71.5	2.1	3.2	21.3	20.6	0.079	80
15	160L - 42	1465	91.8	91.9	0.85	0.81	27.6	7.5	97.8	2.0	3.1	28.4	27.2	0.096	94

This data is provided for guidance only. For confirmation contact Regal Australia for a test report.

# Performance data

HLA series, three phase 380-415V 50Hz

IP55, F class insulation , B class temperature rise

kW	Motor frame	Speed [ r/min ]	400V 50Hz						380V 50Hz			415V 50Hz		Weight of foot mount motor [ kg ]	
			Efficiency		Power factor		Current		Torque			Current	Current		
			at % full load		at % full load		Full load	Locked rotor	Full load	Locked rotor	Break down	Full load	Full load		Moment of inertia
			100	75	100	75	$I_N$	$I_L/I_N$	$T_N$	$T_L/T_N$	$T_B/T_N$	$I_N$	$I_N$		$J=\%GD^2$
		[ % ]	[ % ]	[ % ]	[ % ]	[ A ]		[ Nm ]		[ A ]	[ A ]	[ kg·m <sup>2</sup> ]			
<b>1000 r/min = 6 poles</b>															
0.75	90S -24	940	77.7	77.7	0.70	0.60	2.0	5.5	7.6	2.2	2.7	2.0	1.80	0.0034	17
1.1	90L -24	950	79.9	79.9	0.71	0.64	2.8	6.2	11.1	2.3	2.7	2.8	2.6	0.0041	18
1.5	100L -28	955	81.9	82.3	0.74	0.66	3.6	6.0	15.0	2.4	2.9	3.7	3.6	0.0079	26
2.2	112M -28	960	84.9	85.6	0.72	0.66	5.2	5.7	21.9	2.1	2.6	5.3	5.2	0.0158	32
3	132S -38	965	86.3	87.1	0.76	0.70	6.6	5.9	29.7	1.8	2.2	6.8	6.5	0.035	50
4	132MA -38	965	87.2	88.1	0.75	0.69	8.8	6.4	39.6	2.0	2.7	9.0	8.8	0.041	51
5.5	132MB -38	965	87.9	88.6	0.77	0.71	11.8	6.6	54.4	2.0	2.7	12.2	11.7	0.051	62
7.5	160M -42	975	89.2	89.5	0.79	0.76	15.4	6.4	73.5	2.1	2.9	15.7	15.3	0.098	86
11	160L -42	975	89.9	89.7	0.78	0.71	22.7	6.9	108	2.3	3.3	23.0	22.8	0.131	94
<b>750 r/min = 8 poles</b>															
0.75	100LA -28	715	77.2	76.4	0.66	0.57	2.1	5.7	10.0	2.2	2.3	2.2	2.0	0.011	26
1.1	100LB -28	715	78.6	78.8	0.69	0.61	2.9	5.6	14.7	2.1	2.2	3.0	3.0	0.013	29
1.5	112M -28	710	80.8	80.5	0.63	0.53	4.2	4.7	20.2	2.4	2.7	4.3	4.1	0.026	30
2.2	132S -38	720	84.9	84.9	0.73	0.64	5.1	5.6	29.2	2.2	2.9	5.3	5.1	0.035	50
3	132M -38	715	85.6	85.5	0.73	0.65	7.0	5.8	40.1	2.7	3.1	7.1	6.9	0.045	63
4	160MA -42	720	86.0	85.8	0.72	0.65	9.4	5.7	53.1	2.0	2.9	9.5	9.4	0.078	72
5.5	160MB -42	720	86.6	87.3	0.72	0.63	12.8	6.0	73.0	2.4	3.0	13.0	13.0	0.095	82
7.5	160L -42	720	87.6	88.2	0.75	0.69	16.4	6.3	99.5	2.5	2.9	16.7	16.1	0.135	94

This data is provided for guidance only. For confirmation contact Regal Australia for a test report.

# Dimensional drawings

## Foot mount B3 (IM1001)

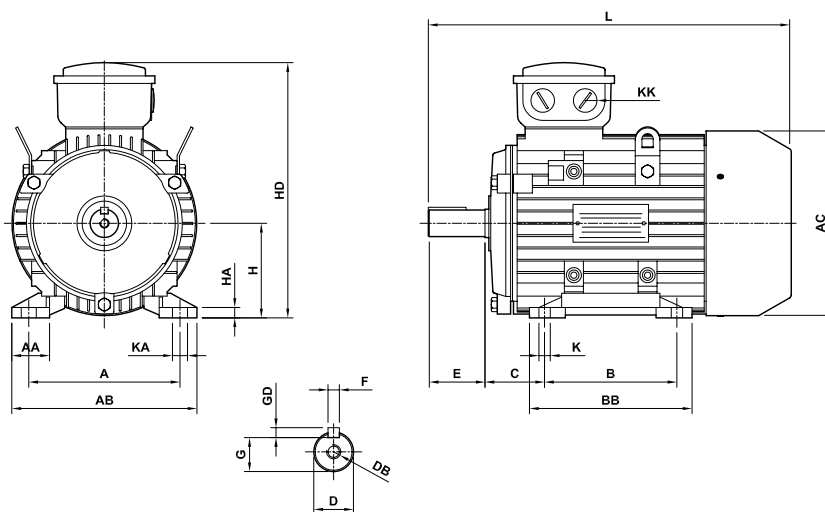

Foot mount B3 (IM1001)

Motor frame	A	AA	AB	AC	B	BB	C	D	DB	E	F	GD	G	H	HA	HD	K	KA	KK	L
<b>80 -19</b>	125	35	157	164	100	125	50	19	M6	40	6	6	15.5	80	9	217	10	14	1xM20	289
<b>90S -24</b>	140	37	173	180	100	125	56	24	M8	50	8	7	20	90	10	236	10	14	2xM20	321
<b>90L -24</b>	140	37	173	180	125	150	56	24	M8	50	8	7	20	90	10	236	10	14	2xM20	347
<b>100L -28</b>	160	40	197	203	140	172	63	28	M10	60	8	7	24	100	12	264	12	16	2xM20	400
<b>112M -28</b>	190	41	227	221	140	180	70	28	M10	60	8	7	24	112	12	290	12	16	2xM25	448
<b>132S -38</b>	216	51	262	260	140	186	89	38	M12	80	10	8	33	132	15	327	12	16	2xM25	478
<b>132M -38</b>	216	51	262	260	178	224	89	38	M12	80	10	8	33	132	15	327	12	16	2xM25	518
<b>160M -42</b>	254	55	304	314	210	260	108	42	M16	110	12	8	37	160	18	420	15	18	2xM32	605
<b>160L -42</b>	254	55	304	314	254	304	108	42	M16	110	12	8	37	160	18	420	15	18	2xM32	650

# Dimensional drawings

## Large flange mount B5 (IM3001)

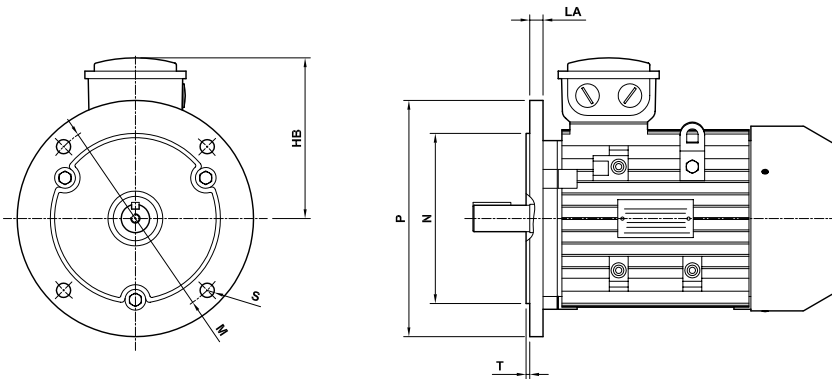

Flange mount B5 (IM3001)

Motor frame	HB	LA	M	N	P	S	T
<b>80 - 19</b>	137	12	165	130	200	12	3.5
<b>90S - 24</b>	146	12	165	130	200	12	3.5
<b>90L - 24</b>	146	12	165	130	200	12	3.5
<b>100L - 28</b>	164	14	215	180	250	15	4.0
<b>112M - 28</b>	178	14	215	180	250	15	4.0
<b>132S - 38</b>	195	14	265	230	300	15	4.0
<b>132M - 38</b>	195	14	265	230	300	15	4.0
<b>160M - 42</b>	260	15	300	250	350	19	5.0
<b>160L - 42</b>	260	15	300	250	350	19	5.0

For further dimensional data, see foot mount data (page 6).

## Small flange (face) B14 (IM3601)

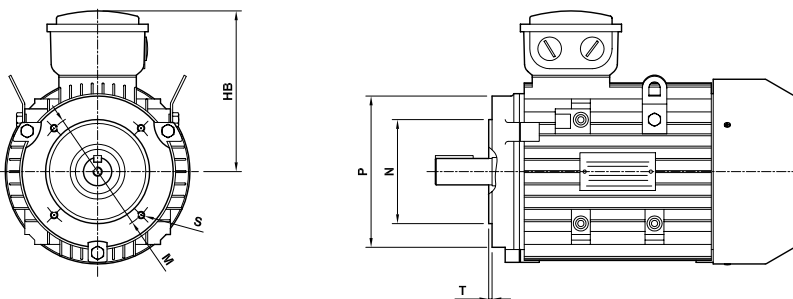

Face mount B14A (IM3601)

Motor frame	HB	M	N	P	S	T
<b>80 - 19</b>	137	100	80	120	M6	3.0
<b>90S - 24</b>	146	115	95	140	M8	3.0
<b>90L - 24</b>	146	115	95	140	M8	3.0
<b>100L - 28</b>	164	130	110	160	M8	3.5
<b>112M - 28</b>	178	130	110	160	M8	3.5
<b>132S - 38</b>	195	165	130	200	M10	3.5
<b>132M - 38</b>	195	165	130	200	M10	3.5
<b>160M - 42</b>	260	215	180	250	M12	4.0
<b>160L - 42</b>	260	215	180	250	M12	4.0

For further dimensional data, see foot mount data (page 6).

Face mount B14B (IM3601)

Motor frame	HB	M	N	P	S	T
<b>80 - 19</b>	137	130	110	160	M8	3.5
<b>90S - 24</b>	146	130	110	160	M8	3.5
<b>90L - 24</b>	146	130	110	160	M8	3.5
<b>100L - 28</b>	164	165	130	200	M10	3.5
<b>112M - 28</b>	178	165	130	200	M10	3.5
<b>132S - 38</b>	195	215	180	250	M12	4.0
<b>132M - 38</b>	195	215	180	250	M12	4.0
<b>160M - 42</b>	available on request					
<b>160L - 42</b>	available on request					

# Dimensional drawings

## Multi-mount option - HLA

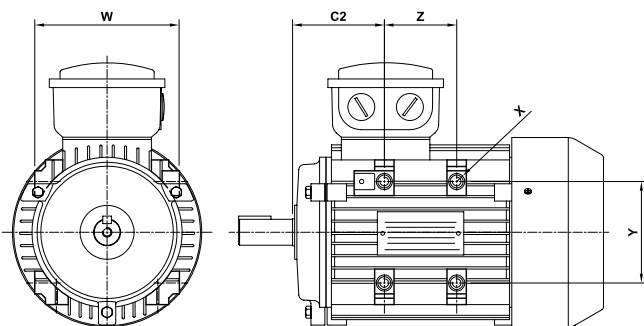

## PAD mount - HLAP

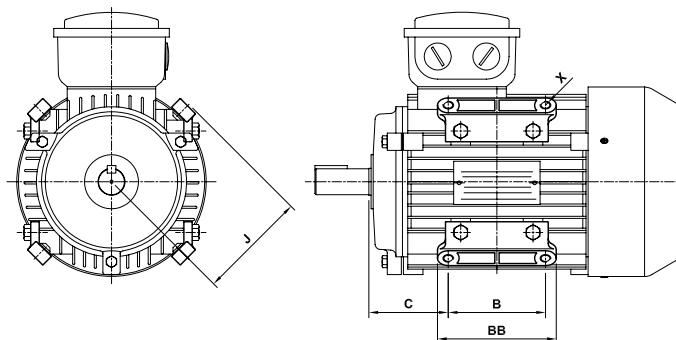

Multi-mount B0

Motor frame	C2	W	X <sup>1)</sup>	Y	Z
<b>80 - 19</b>	79	126	M8	96	42
<b>90S - 24</b>	85	143	M8	102	42
<b>90L - 24</b>	85	143	M8	102	67
<b>100L - 28</b>	94	164	M8	120	78
<b>112M - 28</b>	104	170	M10	120	72
<b>132S - 38</b>	123	206	M10	154	72
<b>132M - 38</b>	123	206	M10	154	110
<b>160M - 42</b>	153	250	M12	190	120
<b>160L - 42</b>	153	250	M12	190	164

<sup>1)</sup> 16 multi-mount mounting pads, 12 tapped or have a provision for tapping. The standard multi-mount offers mounting holes that are vertical or horizontal only.

PAD mount B0

Motor frame	B	BB	C	J	X
<b>80 - 19</b>	90	110	55	102	M12
<b>90S - 24</b>	90	110	61	106	M12
<b>90L - 24</b>	90	110	73.5	106	M12
<b>100L - 28</b>	100	120	83	121	M12
<b>112M - 28</b>	100	120	90	125	M12
<b>132S - 38</b>	102	132	108	158	M16
<b>132M - 38</b>	140	170	108	158	M16
<b>160M - 42</b>	available on request				
<b>160L - 42</b>	available on request				

Pad mount motors are supplied by fitting 4 pads to the multi-mount motors. This option enables the mounting brackets to be fitted in a radial position relative to the motor shaft.



# Dimensional drawings

## Airstream rated PAD mount - HLARP

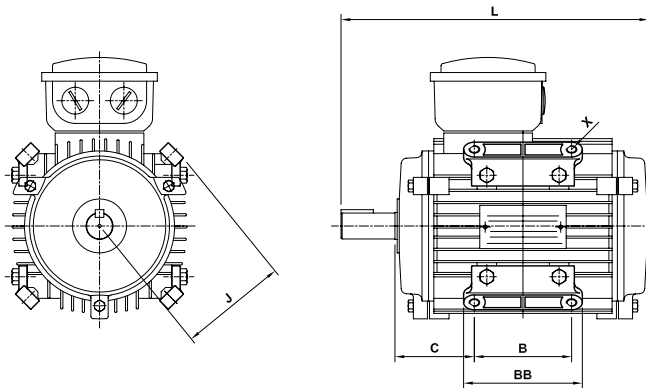

Airstream rated PAD mount B0

Motor frame	B	BB	C	J	L	X
<b>80 - 19</b>	90	110	55	102	240	M12
<b>90S - 24</b>	90	110	61	106	277	M12
<b>90L - 24</b>	90	110	73.5	106	302	M12
<b>100L - 28</b>	100	120	83	121	348	M12
<b>112M - 28</b>	100	120	90	125	382	M12
<b>132S - 38</b>	102	132	108	158	398	M16
<b>132M - 38</b>	140	170	108	158	435	M16
<b>160M - 42</b>	available on request					
<b>160L - 42</b>	available on request					

Pad mount motors are supplied by fitting 4 pads to the multi-mount motors. This option enables the mounting brackets to be fitted in a radial position relative to the motor shaft.

# Modifications and variations

## Terminal box

HLA motors come standard with a terminal box. Alternatively the terminal box can be replaced with a single conduit entry blanking plate and extended leads, including an earth.

Motor frame	Conduit size	HDT
80	M20 x 1.5	192
90S/L	M20 x 1.5	203
100L	M20 x 1.5	234
112M	M25 x 1.5	244
132S/M	M25 x 1.5	291
160M/L	available on request	

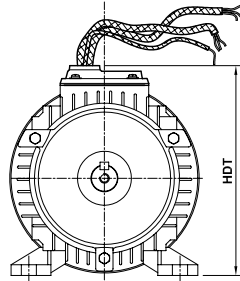

For either terminal box or blanking plate configuration feet can be relocated to provide wiring to the left or right side, or completely removed to enable mounting from the multi-mount pads.

## Bearings

Regal Australia can address applications where bearings need special consideration, including:

- Alternative bearing types
- Low/high temperature bearing grease

## Shafts

Standard HLA motors come with a single output shaft to standard dimensions. The following alternatives are available:

- Double shaft extension
- Special shaft extension
- Stainless steel shaft material

## Endshields

Standard HLA endshields are all aluminium. For frames 90 to 160 they are fitted with steel inserts for the bearings. Cast iron or special endshields for customer applications can be manufactured to specification.

## Slide rails

Regal Australia stock slide rails to suit frame sizes from 80 to 160L. Rail sets are manufactured from cast iron and provided with mounting bolts and nuts between motor and rail.

## Environmental considerations

Where environmental factors need special consideration Regal Australia can provide the following modifications:

- Winding temperature monitors and thermistors
- Anti-condensation heaters
- Separately powered cooling blowers
- Tropic proofing
- Special paint finish
- Higher IP ratings: IP56, IP65, and IP66
- High ambient temperature motors – HLAH with H class insulation

## Special performance

Regal Australia is able to provide HLA motors with special windings. These include:

- 10,12 and 16 pole single speed windings
- Two, three and four speed windings
- Windings for alternative operating voltages and frequencies
- Windings designed for increased outputs and short time ratings